



mQuvée



## WINEMASTER 59D

- mQuvée integrated wine cooler

### PRODUCT SPECIFICATION

- Can be wholly built-in and integrated
- 2 adjustable zones (*5-22 degrees*)
- 6 pull-out wooden shelves (*beechwood*)
- Compressor cooling
- Fan cooling for balanced temperature
- Seamless-door (*door without joins*)
- UV-protected glass door
- Reversible glass door

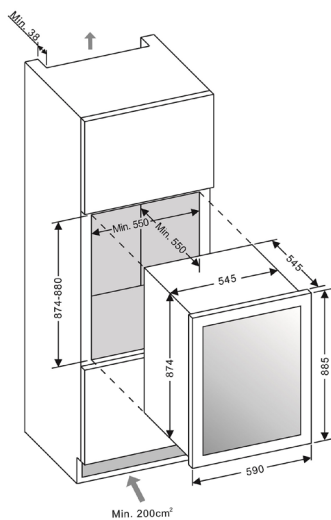

## SPACE FOR 57 BOTTLES

### OTHER SPECIFICATION

- Low vibration for perfect storing your wine bottles
- Automatic defrosting
- Winter safety
- Carbon filter
- Water container for additional adjustment of humidity
- ON/OFF-for electricity
- Adjustable feet 7 cm
- LED-lighting with ON/OFF- button
- Digital display for temperature (white)
- Touch-control panel in wine cooler
- Alarm for low/high temperatures
- Alarm for open door

### AVAILABLE IN

Stainless steel

Powder white

### SIZE AND DIMENSIONS

- Dimensions: (*Width x Height x Depth*)  
59,5 x 88,5 x 56,3 cm
- Weight: 48 kg
- Space for 57 bottles

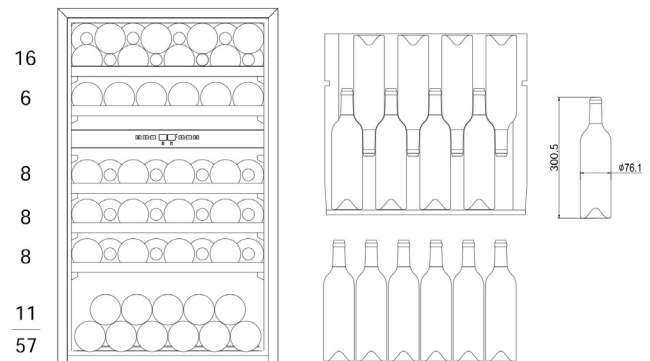

### TECHNICAL DATA

- Voltage: 220-240 V
- Climate class: SN-ST
- Effect: 100 W
- Energy class: A
- Noise level: 39 db(A)
- Annual power consumption: 146.0 kWh