



mQuvée



WINECAVE 30D | 700 - mQuvée built-in wine cooler

PRODUCT SPECIFICATION

- Can be built-in under your kitchen counter or free-standing
- 2 adjustable zones (*5-22 degrees*)
- 5 pull-out wooden shelves (*beechwood*)
- Compressor cooling
- Fan cooling for balanced temperature
- Seamless-door (*door without joins*)
- UV-protected glass door
- Reversible glass door

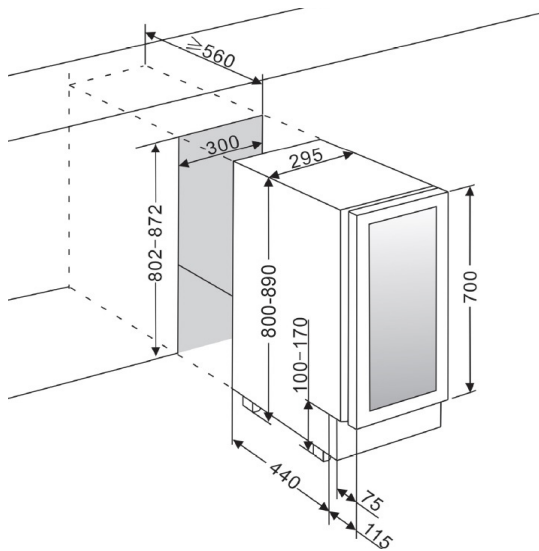

SPACE FOR 16 BOTTLES

SIZE AND DIMENSIONS

- 700 mm door height
- Dimensions: (Width x Height x Depth)
29.5 x 80/89 x 57 cm
- Weight: 27 kg
- Space for 16 bottles

OTHER SPECIFICATION

- Low vibration for perfect storing your wine bottles
- Automatic defrosting
- Winter safety
- Carbon filter
- Water container for additional adjustment of humidity
- ON/OFF-for electricity
- Adjustable feet 7 cm
- LED-lighting with ON/OFF- button
- Digital display for temperature (white)
- Touch-control panel in wine cooler
- Alarm for low/high temperatures
- Alarm for open door

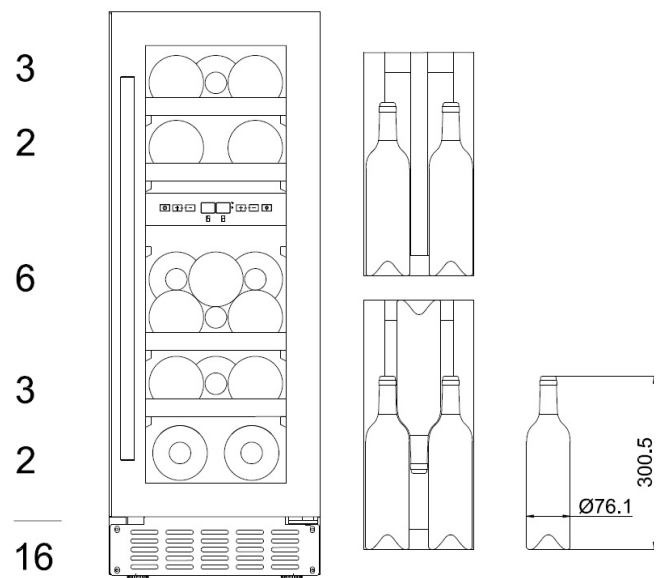

AVAILABLE IN

Anthracite black



Stainless steel



TECHNICAL DATA

- Voltage: 220-240 V
- Noise level: 39 dB (A)
- Energy class: A
- Climate class: SN-ST
- Effect: 85 W
- Annual power consumption: 139.0 kWh