



mQuvée



WINECAVE 60S | 700

- mQuvée built-in wine cooler

PRODUCT SPECIFICATION

- Can be built-in under your kitchen counter or free-standing
- 1 adjustable zones (*5-22 degrees*)
- 5 pull-out wooden shelves (*beechwood*)
- Compressor cooling
- Fan cooling for balanced temperature
- Seamless-door (*door without joins*)
- UV-protected glass door
- Reversible glass door

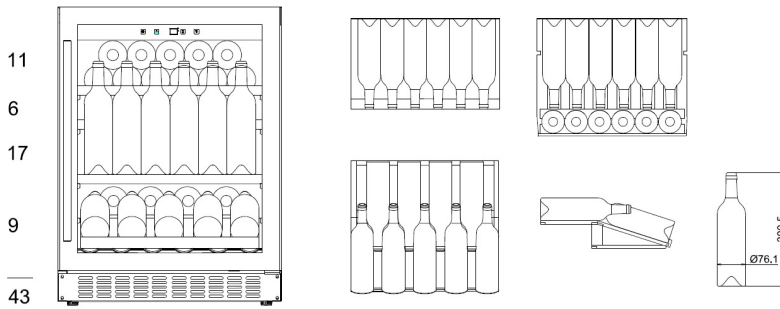

SPACE FOR 50 BOTTLES
(46 BOTTLES IN STAINLESS STEEL)

OTHER SPECIFICATION

- Low vibration for perfect storing your wine bottles
- Automatic defrosting
- Winter safety
- Carbon filter
- Water container for additional adjustment of humidity
- ON/OFF-for electricity
- Adjustable feet 7 cm
- LED-lighting with ON/OFF- button
- Digital display for temperature (white)
- Touch-control panel in wine cooler
- Alarm for low/high temperatures
- Alarm for open door

SIZE AND DIMENSIONS

- 700 mm door height
- Dimensions: (*Width x Height x Depth*) 59.5 x 80/89 x 57 cm
- Weight: 46 kg
- Space for 46/50 bottles

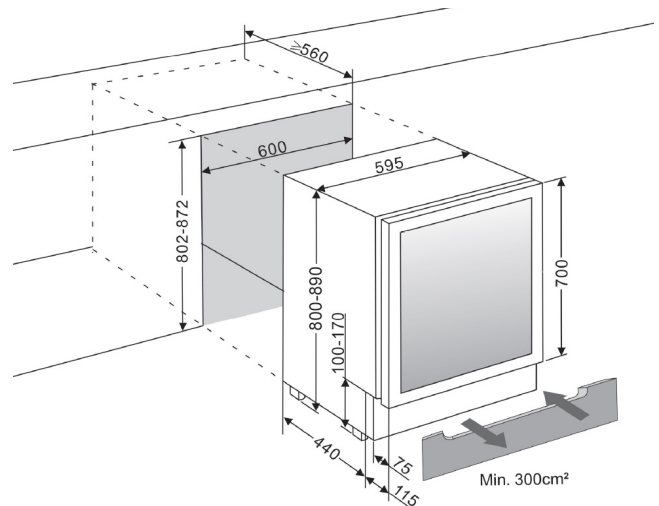

TECHNICAL DATA

- Voltage: 220-240 V
- Noise level: 40 dB (A)
- Energy class: A
- Climate class: SN-ST
- Effect: 100 W
- Power consumption: 0.39 kWh/24 h
- Annual power consumption: 145.0 kWh

AVAILABLE IN

Modern



Anthracite Black



Stainless steel



Custom Made

