



mQuvée



WineCave 15S | 720

mQuvée built-in wine cooler

PRODUCT SPECIFICATION

- Can be built-in under your kitchen counter or free-standing
- Adjustable zone (5-20 degrees)
- Compressor cooling
- Fan cooling for balanced temperature
- Seamless-door (*door without joins*)
- UV-protected glass door
- Reversible glass door

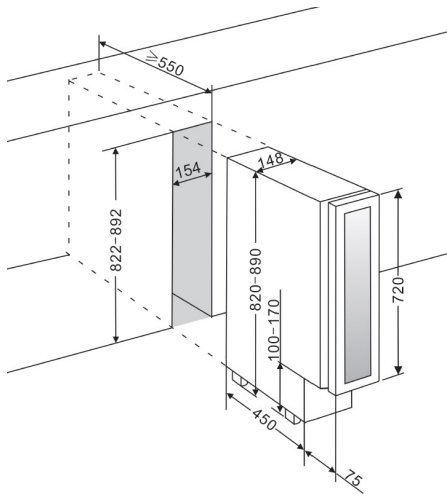

SPACE FOR 7 BOTTLES

SIZE AND DIMENSIONS

- 720 mm door height
- Dimensions: (Width x Height x Depth)
14,8 x 82/89 x 52,5 cm
- Weight: 19 kg
- Space for 7 bottles

OTHER SPECIFICATION

- Low vibration for perfect storing your wine bottles
- Automatic defrosting
- Winter safety
- Water container for additional adjustment of humidity
- ON/OFF-for electricity
- Adjustable feet 7 cm
- LED-lighting with ON/OFF- button
- Digital display for temperature (white)
- Touch-control panel in wine cooler
- Alarm for low/high temperatures
- Alarm for open door

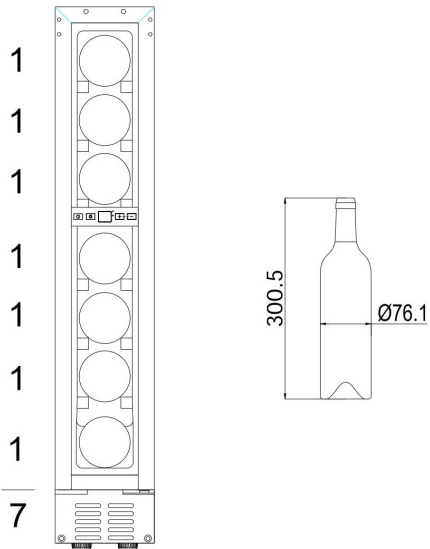

AVAILABLE IN

Powder white

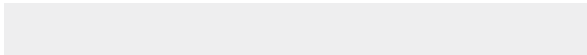

Stainless steel



Anthracite Black



TECHNICAL DATA

- Voltage: 220-240 V
- Noise level: 40 dB (A)
- Energy class: G
- Climate class: N-ST
- Effect: 60 W
- Annual power consumption: 142 kWh