



mQuvée

WINESTORE 82

- mQuvée wine cabinet

PRODUCT SPECIFICATION

- Wine cabinet for both free-standing and built in
- Adjustable temperature (*5-22 degrees*)
- 2 sliding wooden shelves (*beechwood*)
- Compressor cooling
- Fan cooling for balanced temperature
- Seamless-door (*door without joins*)
- Reversible solid door with lock & vertical handle



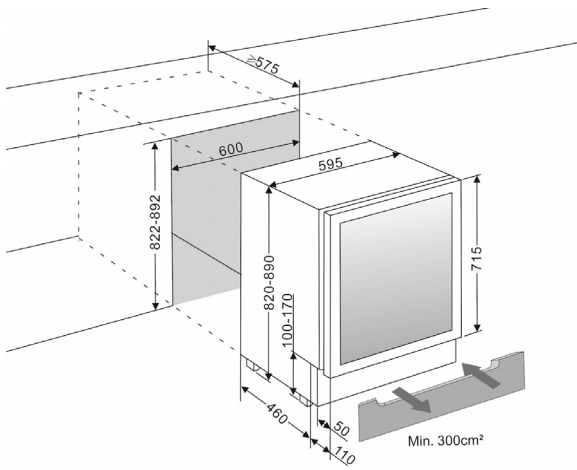

SPACE FOR 66 BOTTLES

OTHER SPECIFICATION

- Low vibration for perfect storing your wine bottles
- Automatic defrosting
- Winter safety
- Carbon filter
- Water container for additional adjustment of humidity
- ON/OFF-for electricity
- Adjustable feet 7 cm
- LED-lighting with ON/OFF- button
- Digital display for temperature (white)
- Alarm for low/high temperatures
- Alarm for open door

AVAILABLE IN

Anthracite black

Powder white

SIZE AND DIMENSIONS

- Dimensions: (*Width x Height x Depth*)
59,5 x 82/89 x 57 cm
- Weight: 43 kg
- Space for 66 bottles

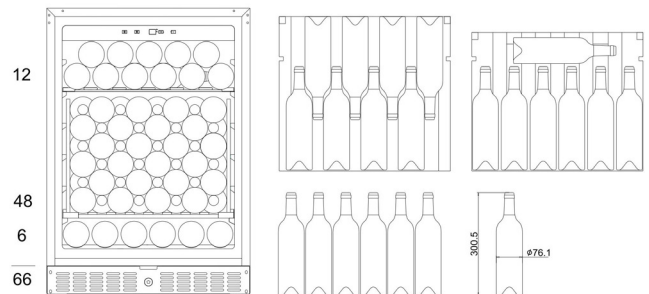

TECHNICAL DATA

- Voltage: 220-240 V
- Climate class: SN-ST
- Effect: 100 W
- Energy class: A+
- Noise level: 40 db
- Annual power consumption: 110 kWh