



mQuvée

## WINECAVE 60D | 700 mQuvée built-in wine cooler



### PRODUCT SPECIFICATION

- Can be built-in under your kitchen counter or free-standing
- 2 adjustable zones (5-20 degrees)
- 4 pull-out wooden shelves (beechwood)
- Compressor cooling
- Fan cooling for balanced temperature
- Seamless-door (*door without joins*)
- UV-protected glass door
- Reversible glass door

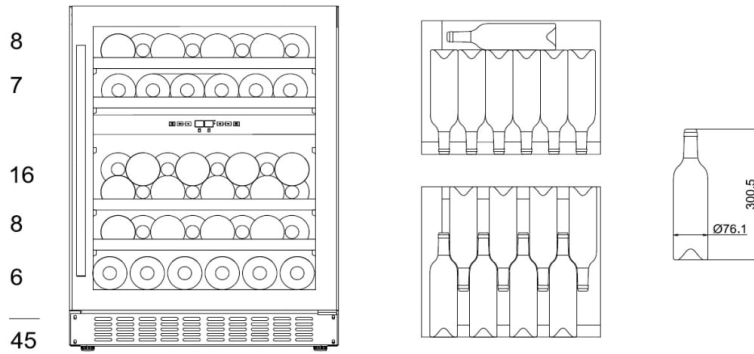

**SPACE FOR 45 BOTTLES**

**OTHER SPECIFICATION**

- Low vibration for perfect storing your wine bottles
- Automatic defrosting
- Winter safety
- Carbon filter
- Water container for additional adjustment of humidity
- ON/OFF-for electricity
- Adjustable feet 8 cm
- LED-lighting with ON/OFF- button
- Digital display for temperature (white)
- Touch-control panel in wine cooler
- Alarm for low/high temperatures
- Alarm for open door

**SIZE AND DIMENSIONS**

- 700 mm door height
- Dimensions: (*Width x Height x Depth*) 59.5 x 82/90 x 55.5 cm
- Weight: 49 kg
- Space for 45 bottles

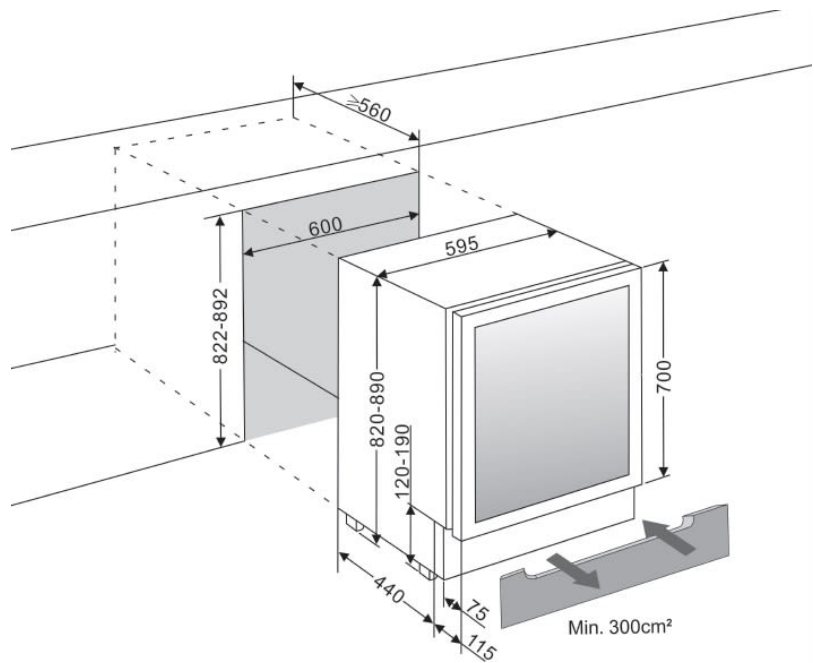

**TECHNICAL DATA**

- Voltage: 220-240 V
- Noise level: 36 dB (A)
- Energy class: F
- Climate class: ST
- Effect: 100 W
- Annual power consumption: 103 kWh

**AVAILABLE IN**

Stainless steel



Anthracite black



Custom made

