



mQuvée



WINECAVE 30D | 720

- mQuvée built-in wine cooler

PRODUCT SPECIFICATION

- Can be built-in under your kitchen counter or free-standing
- 2 adjustable zones (5-20 degrees)
- 5 pull-out wooden shelves (*beechwood*)
- Compressor cooling
- Fan cooling for balanced temperature
- Seamless-door (*door without joins*)
- UV-protected glass door
- Reversible glass door

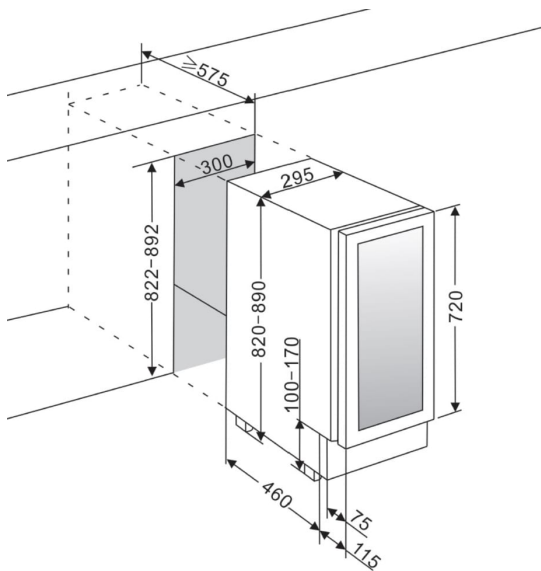

SPACE FOR 16 BOTTLES

SIZE AND DIMENSIONS

- 720 mm door height
- Dimensions: (*Width x Height x Depth*)
29.5 x 82/89 x 57 cm
- Weight: 30 kg
- Space for 16 bottles

OTHER SPECIFICATION

- Low vibration for perfect storing your wine bottles
- Automatic defrosting
- Winter safety
- Carbon filter
- Water container for additional adjustment of humidity
- ON/OFF-for electricity
- Adjustable feet (8 cm)
- LED-lighting with ON/OFF- button
- Digital display for temperature (white)
- Touch-control panel in wine cooler
- Alarm for low/high temperatures
- Alarm for open door

Model WCD30

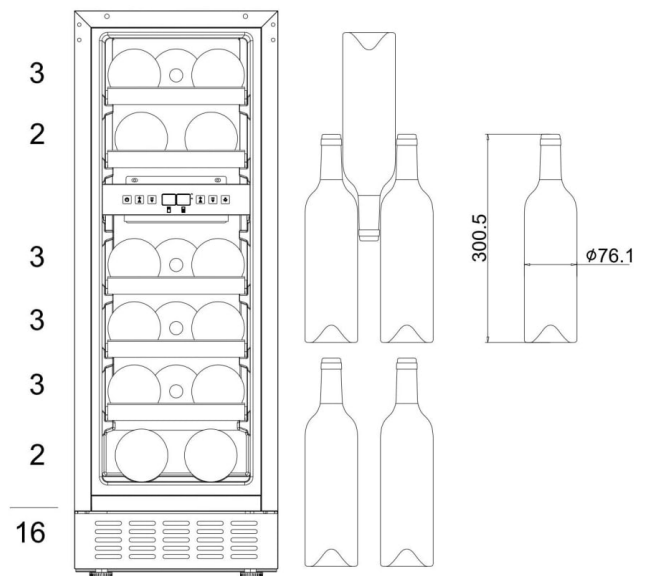

AVAILABLE IN

Powder white

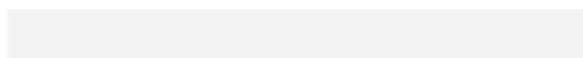

Stainless steel



TECHNICAL DATA

- Voltage: 220-240 V
- Noise level: 39 dB (A)
- Energy class: F
- Climate class: SN-ST
- Effect: 85 W
- Annual power consumption: 98 kWh