



mQuvée



WineCave Exclusive 187 mQuvée built-in wine cooler

PRODUCT SPECIFICATION

- Can be built-in under your kitchen counter or free-standing
- 2 adjustable zones (*5-20 degrees*)
- 14 pull-out wooden shelves (*beechwood*)
- Compressor cooling
- Fan cooling for balanced temperature
- Seamless-door (*door without joins*)
- UV-protected glass door
- Reversible glass door

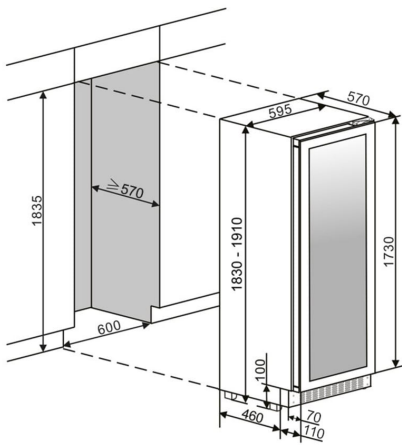

NOTE: WINE COOLER MUST BE SECURELY ATTACHED TO THE WALL OR THE FLOOR.

OTHER SPECIFICATION

- Low vibration for perfect storing your wine bottles
- Automatic defrosting
- Winter Safety System
- Carbon filter
- Water container for additional adjustment of humidity
- ON/OFF-for electricity
- Adjustable feet 8 cm
- LED-lighting with ON/OFF- button
- Digital display for temperature (white)
- Touch-control panel in wine cooler
- Alarm for low/high temperatures
- Alarm for open door
- Practical hinge that minimises the door's swing radius

SIZE AND DIMENSIONS

- Dimensions: (*Width x Height x Depth*)
59.5 x 183/191 x 57 cm
- Weight: 93 kg
- Space for 123 bottles

SPACE FOR 123 BOTTLES

TECHNICAL DATA

- Voltage: 220-240 V
- Effect: 160 W
- Annual power consumption: 174 kWh
- Energy class: G
- Sound level: 41 dB (A)

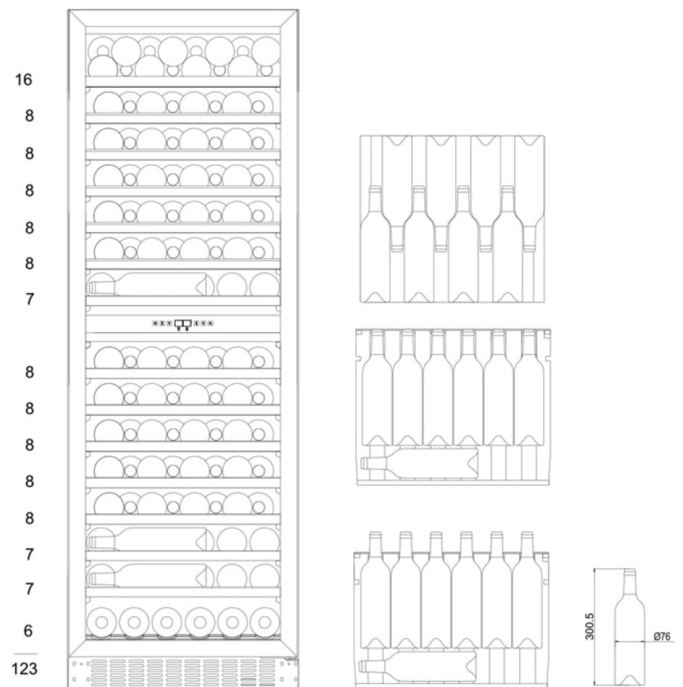

AVAILABLE IN

Stainless steel

Powder White

Anthracite black