



mQuvée



WineKeeper 70D mQuvée integrated wine cooler

PRODUCT SPECIFICATION

- Can be built-in under your kitchen counter or free-standing
- 2 adjustable zones (5-20 degrees)
- 9 pull-out wooden shelves (beechwood)
- Compressor cooling
- Fan cooling for balanced temperature
- Seamless-door (door without joins)
- UV-protected glass door
- Reversible glass door

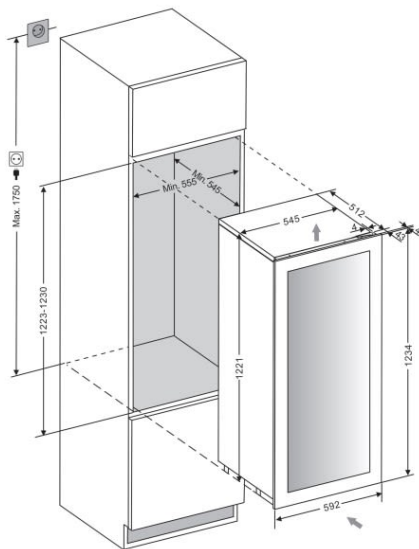

SPACE FOR 70 BOTTLES

OTHER SPECIFICATION

- Low vibration for perfect storing your wine bottles
- Automatic defrosting
- Winter safety
- Carbon filter
- Water container for additional adjustment of humidity
- ON/OFF-for electricity
- Adjustable feet 1 cm
- LED-lighting with ON/OFF- button
- Digital display for temperature (white)
- Touch-control panel in wine cooler
- Alarm for low/high temperatures
- Alarm for open door

AVAILABLE IN

Stainless steel



Anthracyte black



SIZE AND DIMENSIONS

- Dimensions: (*Width x Height x Depth*)
59 x 123.4 x 55.9 cm
- Weight: 61 kg
- Space for 70 bottles

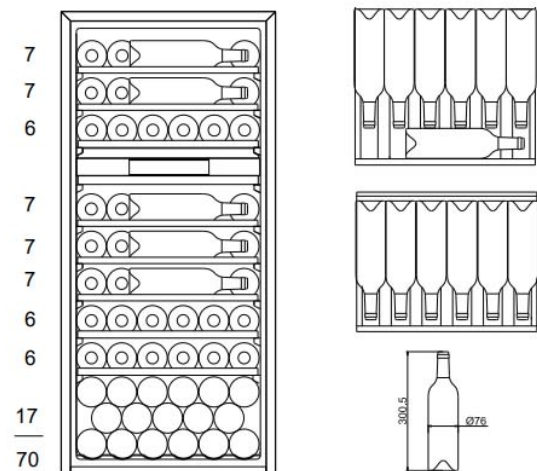

TECHNICAL DATA

- Voltage: 220-240 V
- Climate class: ST
- Effect: 130 W
- Energy class: G
- Noise level: 40 dB (A)
- Annual power consumption: 170 kWh